

NMRV-NMRV

精禾科技股份有限公司
 台中市西屯區福中二街10巷22號1樓
 TEL : 04-23501313 傳真 : 04-23501389
 電子信箱 : genho.com@msa.hinet.net
 謙虛的態度、專業的服務

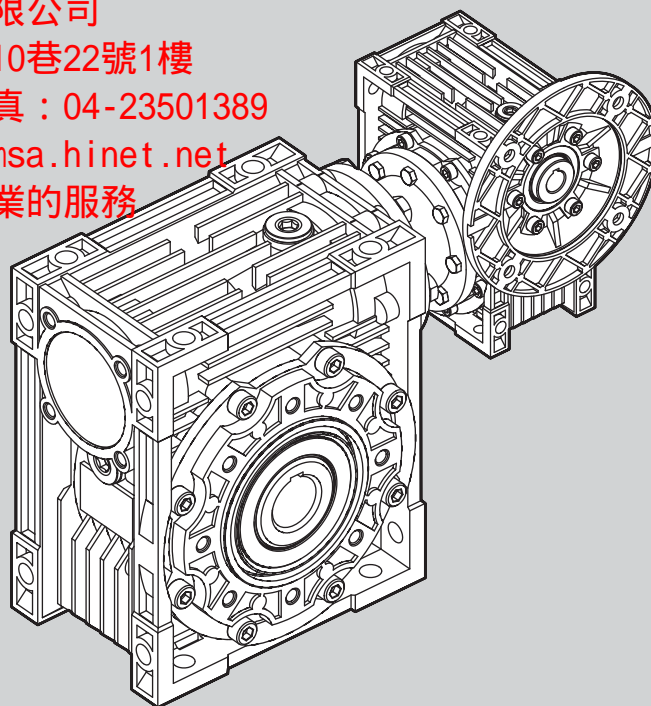

NMRV-NMRV型號標記 Model & marker

NMRV-040/090-500-VS-F1(FA)-AS-80B5-0.75kW-AS1

NMRV+NMRV	雙蝸輪減速機 Combined worm geared motor	PAM	聯接馬達 Fitted for motor coupling
NRV+NMRV	配輸入軸雙蝸輪減速機 Combined worm reduction unit	0.75kW	馬達功率 Electric motor power
040/090	蝸輪減速機中心距 Center distance	F1(FA)	輸出法蘭位置及型號 Output flange
500	減速比 Reduction ratio	AB	雙向輸出軸 Double output shaft
VS	雙向輸入軸 Double input shaft	80B5	馬達框號和安裝結構形式 Motor mounting facility
AS	單向輸出軸 Single output shaft	AS1	安裝方式 Mounting position

NMRV-NMRV安裝方式 Mounting positions

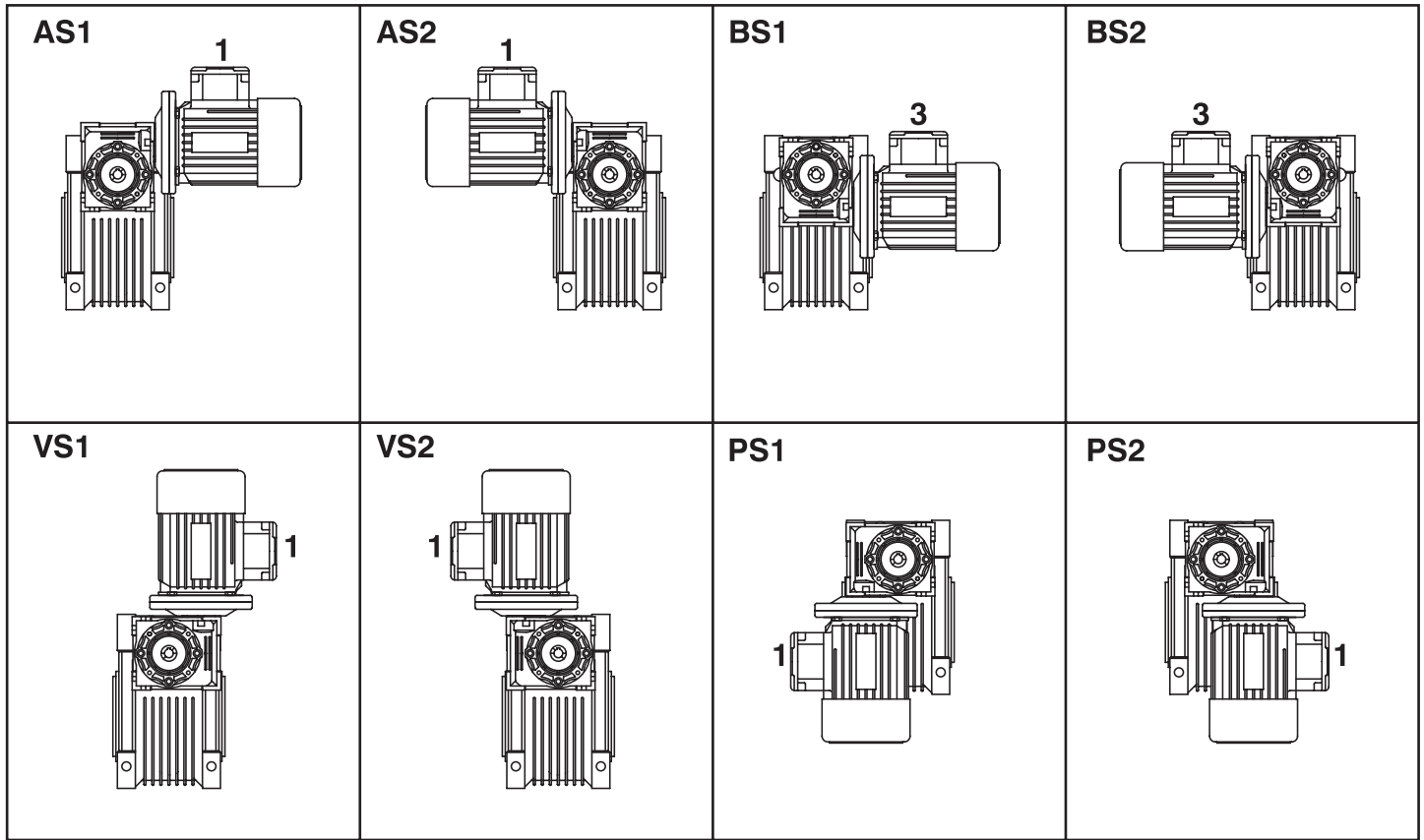

法蘭位置 Flange F-FL

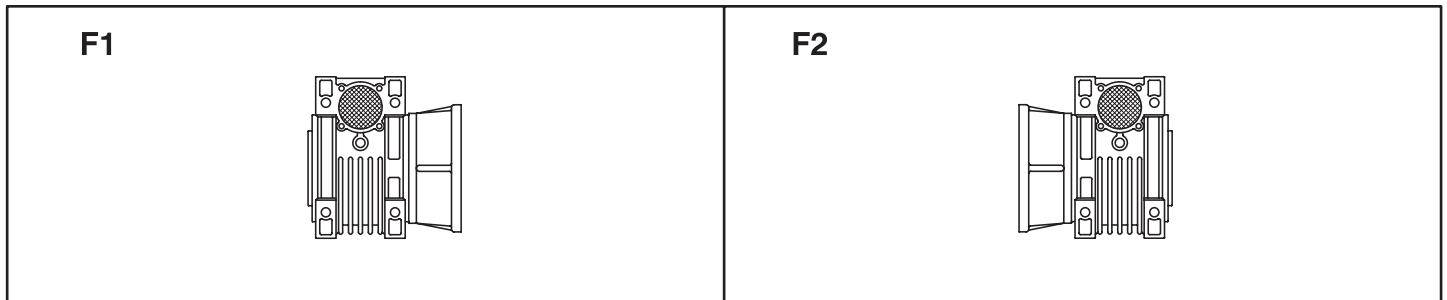

接線盒安裝方式 Pos. of terminal box

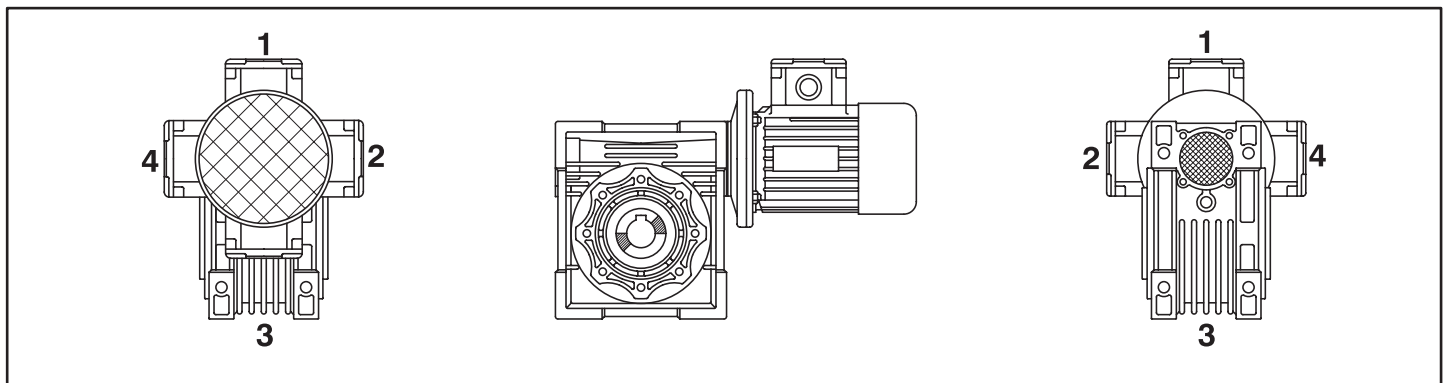

NMRV-NMRV參數表 Parameter table

*n1=1400rpm

	i	n2	kW1	M2 (Nm)	i1	i2
NRV 030/040	300	4.7	0.08	73	10	30
	400	3.5	0.06	65	10	40
	500	2.8	0.04	61	20	25
	600	2.3	0.04	73	20	30
	750	1.9	0.04	73	25	30
	900	1.6	0.03	73	30	30
	1200	1.2	0.02	65	30	40
	1500	0.9	0.02	73	50	30
	1800	0.8	0.02	73	60	30
	2400	0.58	0.01	65	60	40
	3200	0.4	0.01	65	80	40
	4000	0.4	0.01	33	50	80
5000	0.28	0.01	29	50	100	
NRV 030/050	300	4.7	0.15	145	10	30
	400	3.5	0.1	124	10	40
	500	2.8	0.09	120	10	50
	600	2.3	0.08	145	20	30
	750	1.9	0.07	145	25	30
	900	1.6	0.06	145	30	30
	1200	1.2	0.04	124	30	40
	1500	0.93	0.04	145	50	30
	1800	0.78	0.04	145	60	30
	2400	0.6	0.03	124	60	40
	3000	0.5	0.02	120	60	50
	4000	0.35	0.02	82	50	80
4800	0.29	0.02	82	60	80	
NRV 030/063	300	4.7	0.24	230	7.5	40
	400	3.5	0.19	230	10	40
	500	2.8	0.15	216	10	50
	600	2.3	0.13	230	15	40
	750	1.9	0.11	216	15	50
	900	1.6	0.09	198	15	60
	1200	1.2	0.08	230	30	40
	1500	0.93	0.06	216	30	50
	1800	0.78	0.05	198	30	60
	2400	0.58	0.05	230	60	40
	3000	0.47	0.04	216	60	50
	4000	0.35	0.03	172	50	80
5000	0.28	0.02	150	50	100	
NRV 040/075	300	4.7	0.36	390	10	30
	400	3.5	0.27	360	10	40
	500	2.8	0.21	320	10	50
	600	2.3	0.19	390	20	30
	750	1.9	0.16	390	25	30
	900	1.6	0.14	390	30	30
	1200	1.2	0.11	360	30	40
	1500	0.93	0.1	390	50	30
	1800	0.78	0.09	390	60	30
	2400	0.58	0.07	360	60	40
	3000	0.47	0.05	320	60	50
	4000	0.35	0.04	250	50	80
5000	0.28	0.03	230	50	100	
NRV 040/090	300	4.7	0.56	610	7.5	40
	400	3.5	0.43	610	10	40
	500	2.8	0.34	560	10	50
	600	2.3	0.3	610	15	40
	750	1.9	0.23	560	15	50
	900	1.6	0.19	505	15	60
	1200	1.2	0.17	610	30	40
	1500	0.93	0.14	560	30	50
	1800	0.78	0.11	505	30	60
	2400	0.58	0.11	610	60	40
	3000	0.47	0.08	560	60	50
	4000	0.35	0.08	460	50	80
5000	0.28	0.06	410	50	100	
NRV 050/110	300	4.7	0.95	1100	10	30
	400	3.5	0.69	1030	10	40
	500	2.8	0.56	1000	10	50
	600	2.3	0.48	1030	15	40
	750	1.9	0.43	1100	25	30
	900	1.6	0.38	1100	30	30
	1200	1.2	0.27	1030	30	40
	1500	0.93	0.28	1100	50	30
	1800	0.78	0.23	1100	60	30
	2400	0.58	0.17	1030	60	40
	3000	0.47	0.14	1000	60	50
	4000	0.35	0.12	780	50	80
5000	0.28	0.09	710	50	100	
NRV 063/130	300	4.7	1.48	1760	10	30
	400	3.5	1.09	1650	10	40
	500	2.8	0.86	1550	10	50
	600	2.3	0.76	1650	15	40
	750	1.9	0.66	1760	25	30
	900	1.6	0.58	1760	30	30
	1200	1.2	0.43	1650	30	40
	1500	0.93	0.39	1760	50	30
	1800	0.78	0.35	1760	60	30
	2400	0.58	0.25	1650	60	40
	3000	0.47	0.2	1550	60	50
	4000	0.35	0.15	1220	50	80
5000	0.28	0.11	1100	50	100	

NMRV-NMRV外形尺寸 Dimensions

NMRV 025 - NMRV 030

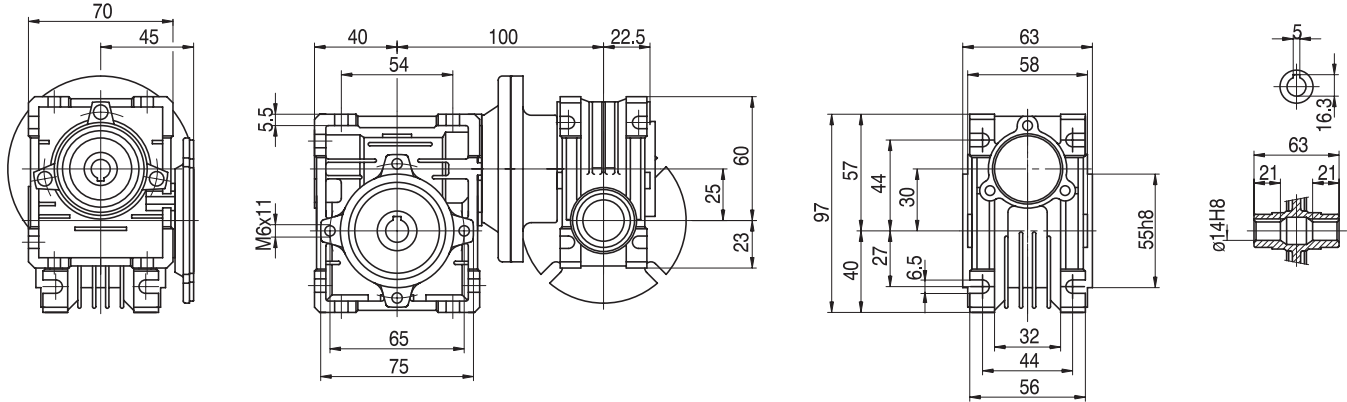

NMRV 025 - NMRV 040

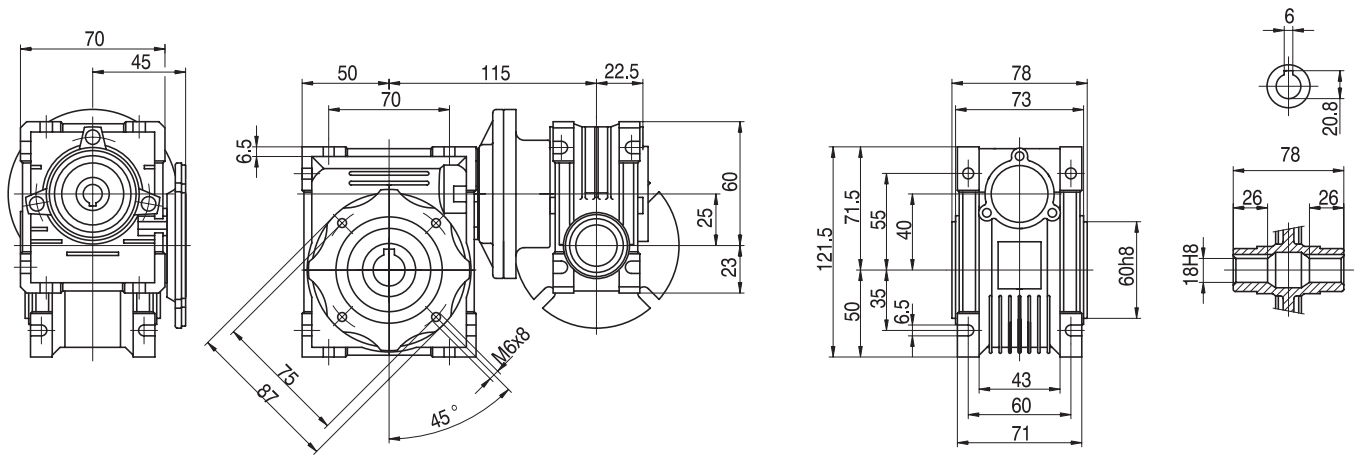

NMRV 030 - NMRV 040

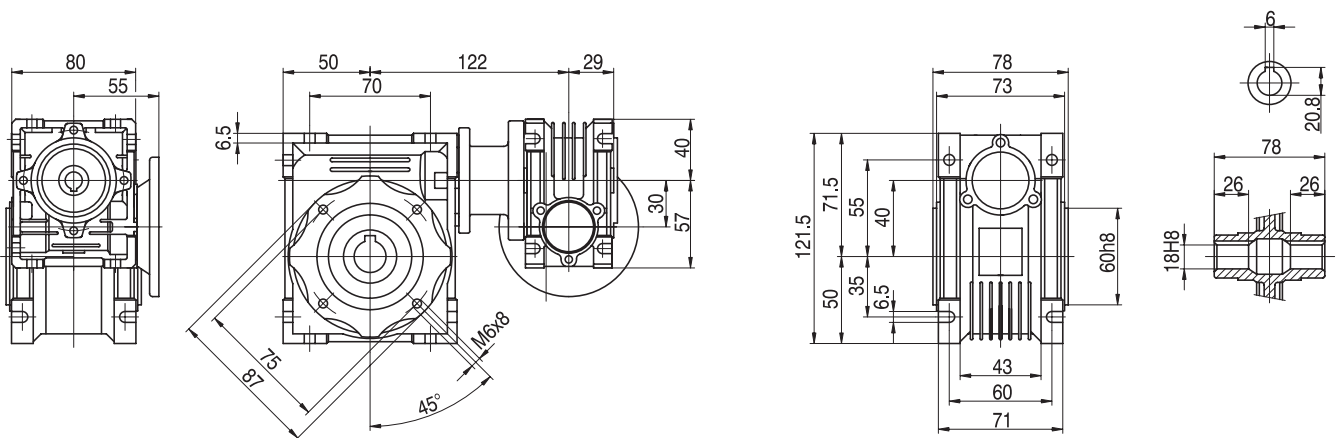

NMRV-NMRV外形尺寸 Dimensions

NMRV 030 - NMRV 050

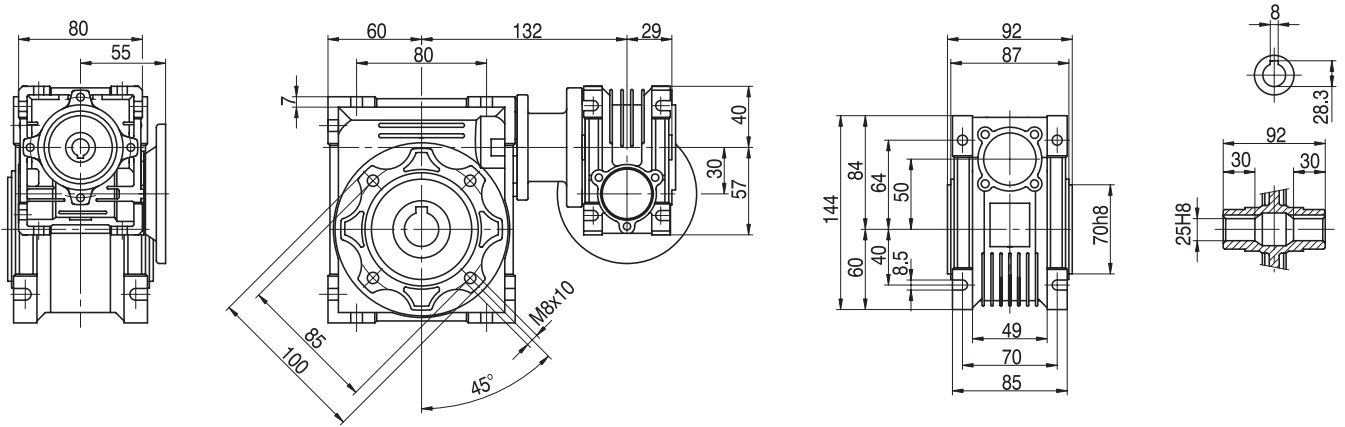

NMRV 030 - NMRV 063

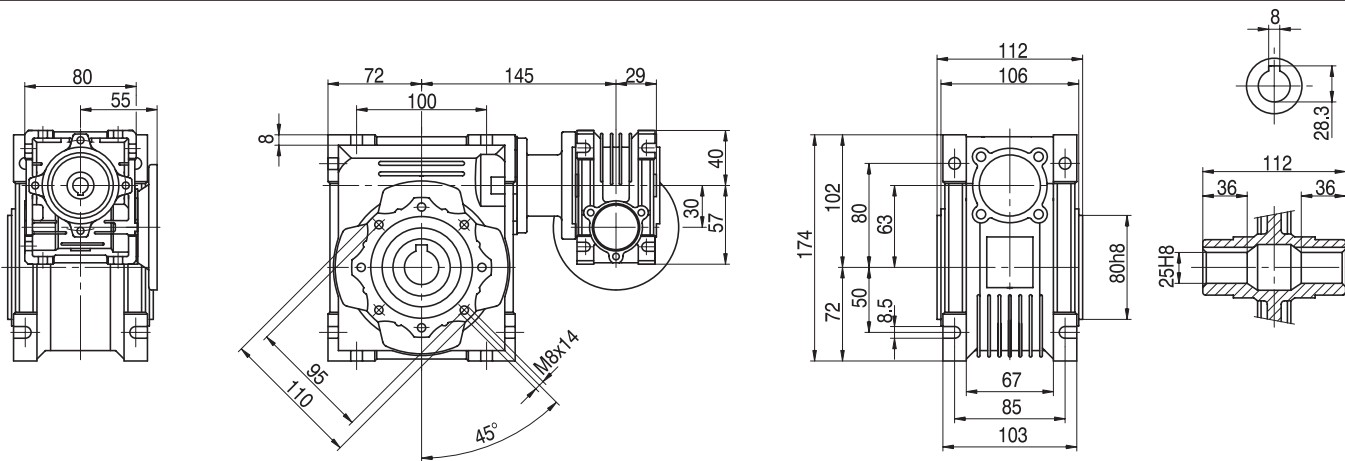

NMRV 040 - NMRV 075

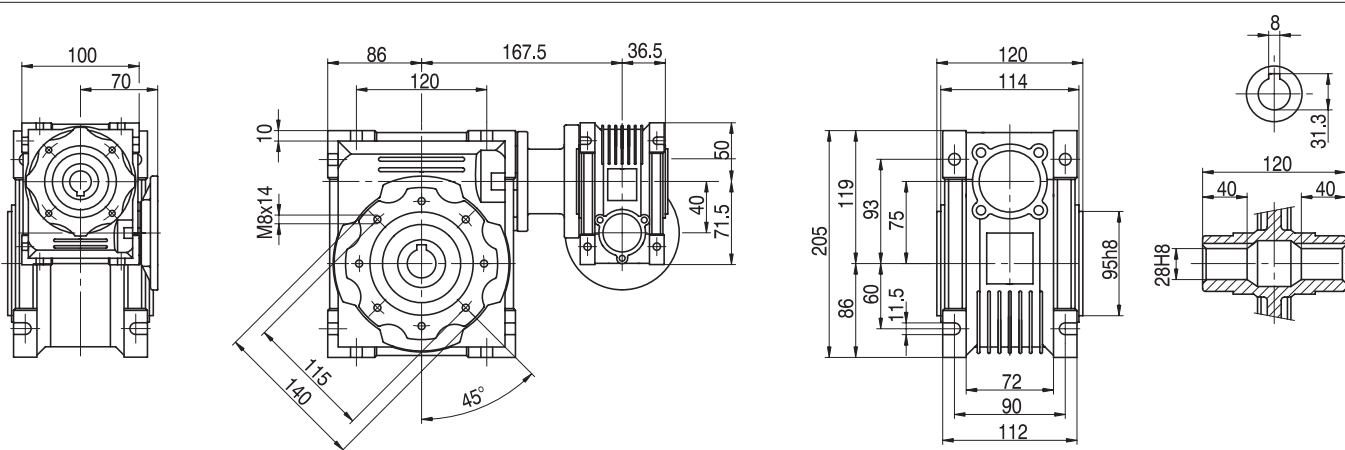

NMRV-NMRV外形尺寸 Dimensions

NMRV 040 - NMRV 090

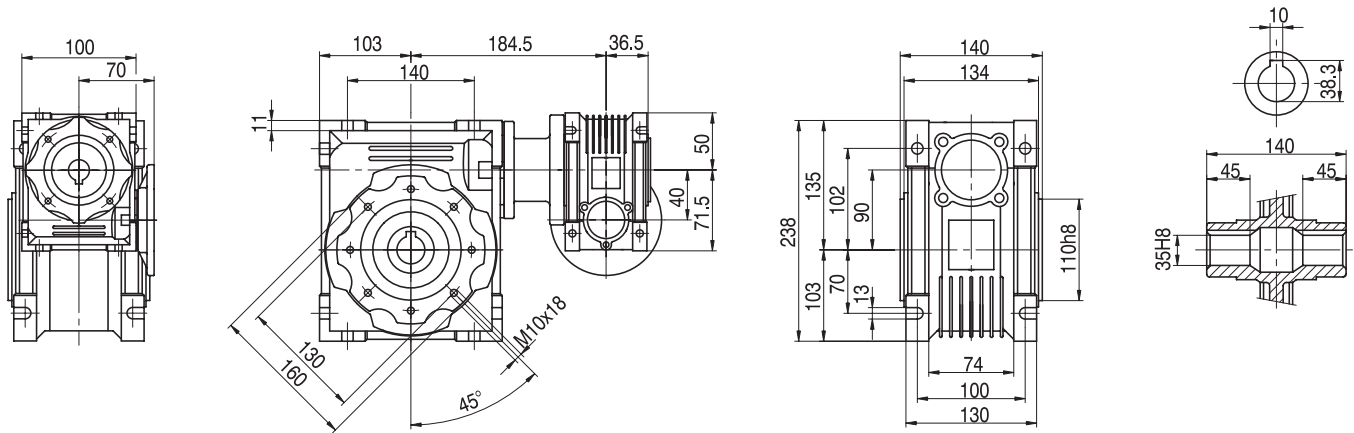

NMRV 050 - NMRV 110

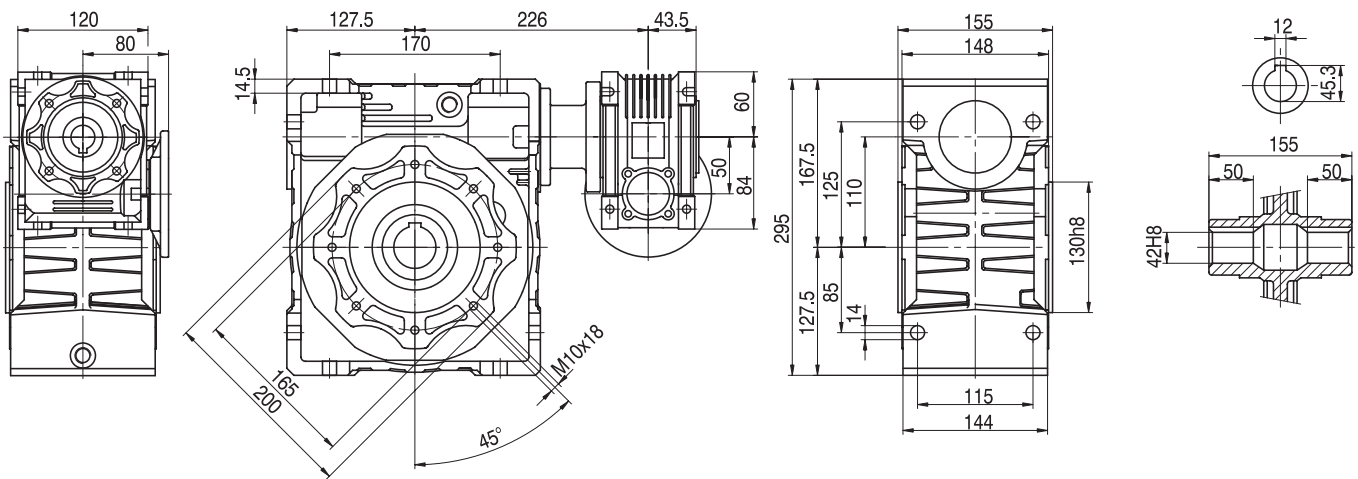

NMRV 063 - NMRV 130

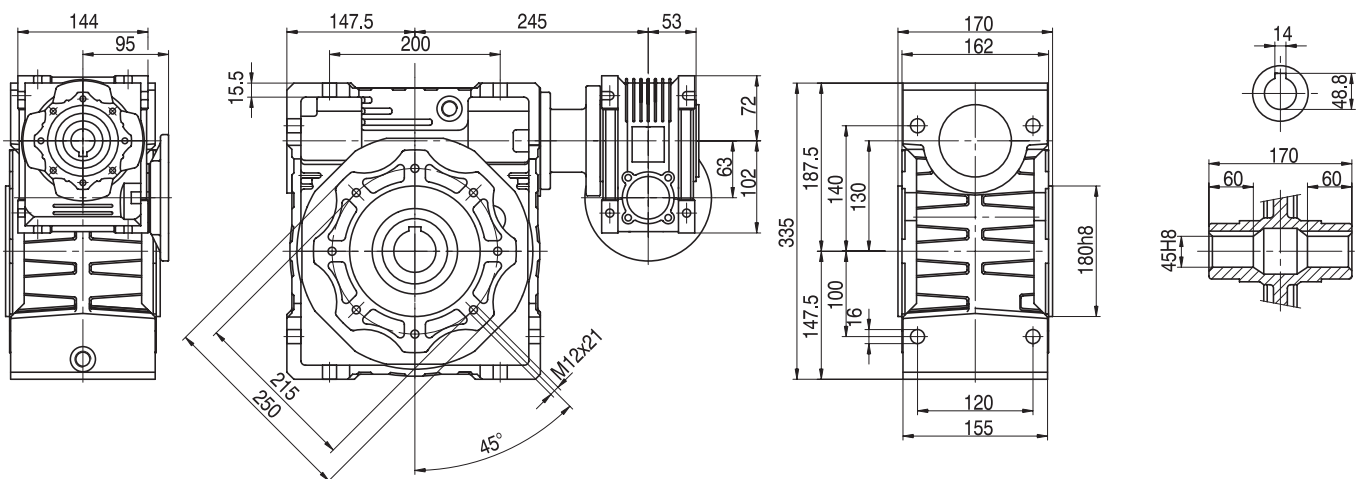

NRV-NMRV 外形尺寸 Dimensions

NMRV 063 - NMRV 150

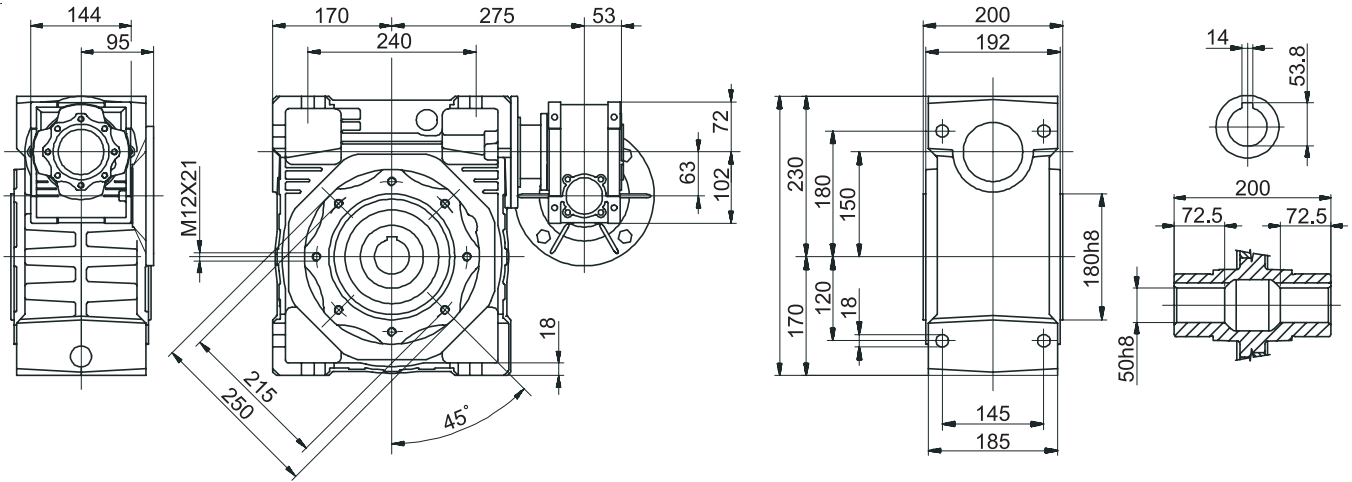

NRV-NMRV 外形尺寸 Dimensions

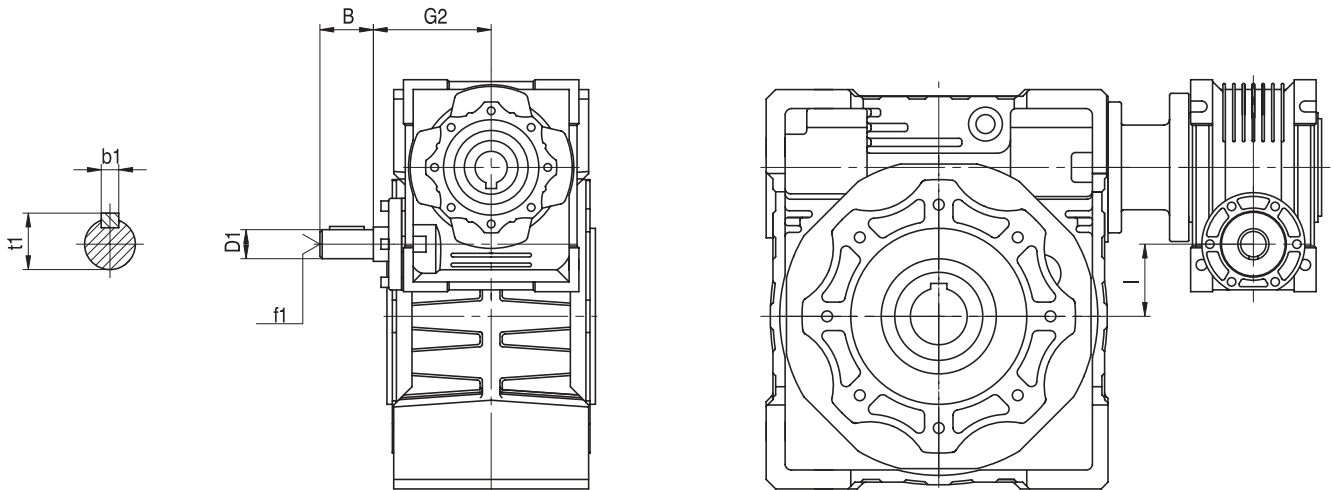

NRV-NMRV	030-040	030-050	030-063	040-075	040-090	050-110	063-130	063-150
B	20	20	20	23	23	30	40	40
D1	9 j6	9 j6	9 j6	11 j6	11 j6	14 j6	19 j6	19 j6
G2	51	51	51	60	60	74	90	90
l	10	20	33	35	50	50	67	87
b1	3	3	3	4	4	5	6	6
f1	-	-	-	-	-	M6	M6	M6
t1	10.2	10.2	10.2	12.5	12.5	16	21.5	21.5