

無段變速機 Variator

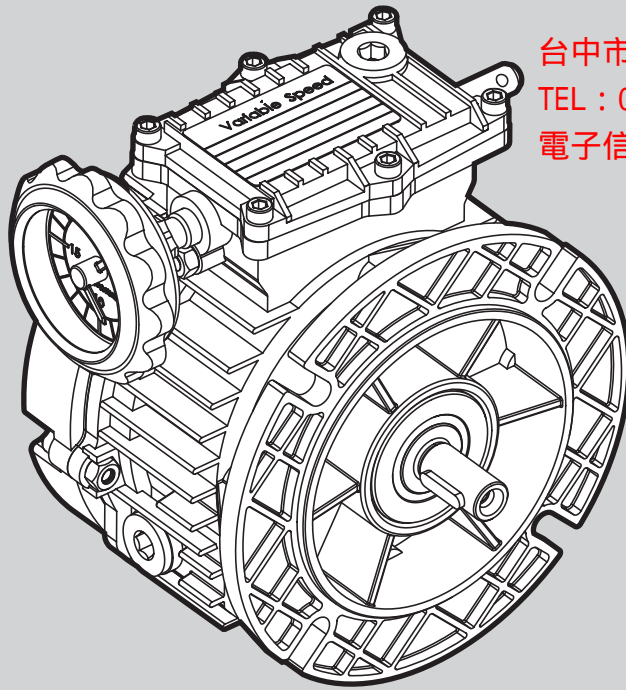

精禾科技股份有限公司  
 台中市西屯區福中二街10巷22號1樓  
 TEL : 04-23501313 傳真 : 04-23501389  
 電子信箱 : genho.com@msa.hinet.net  
 謙虛的態度、專業的服務

結構分解圖 Structural breakdown drawing

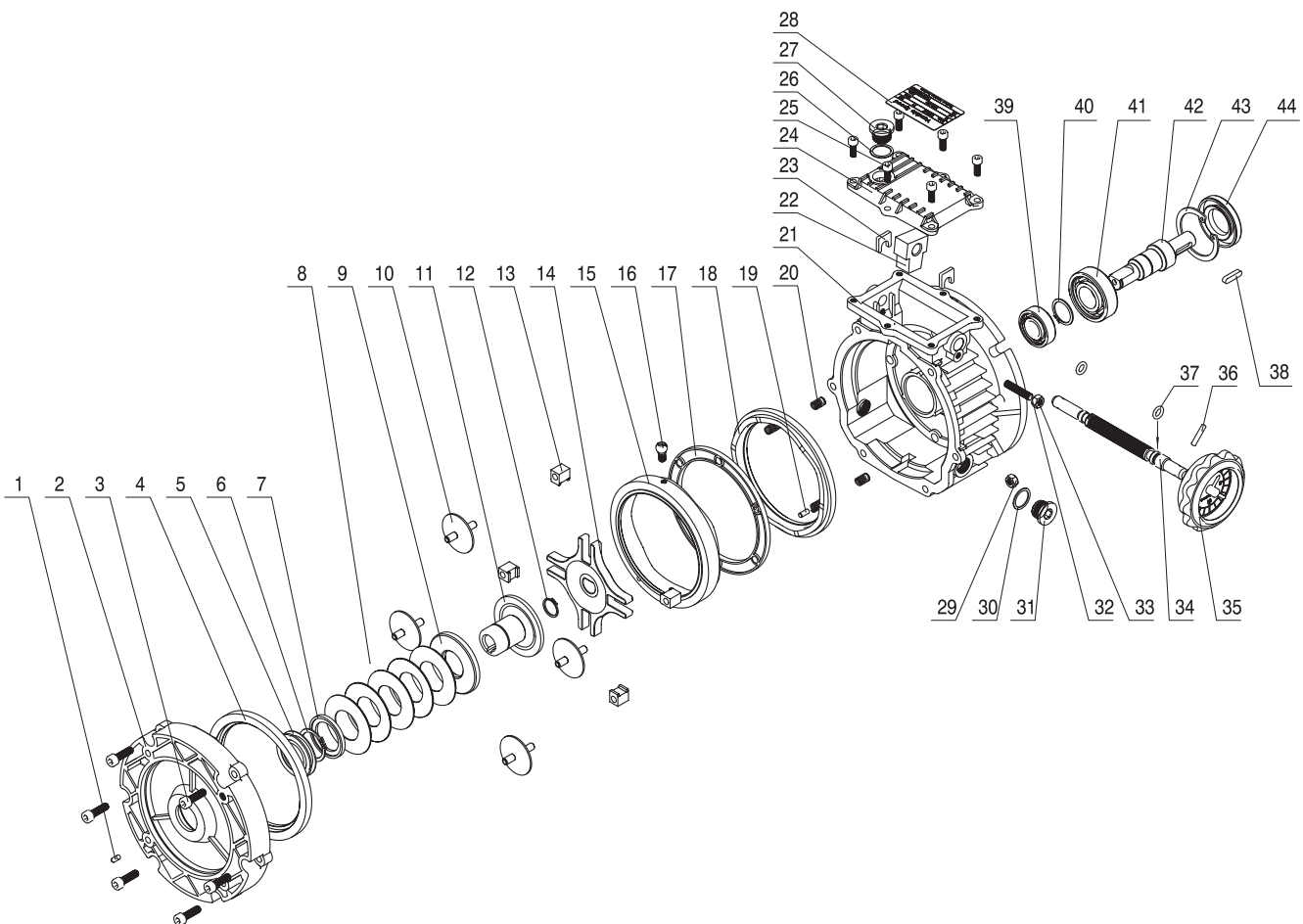

## 型號標記 Model & marker

**TXF 005 - B3**

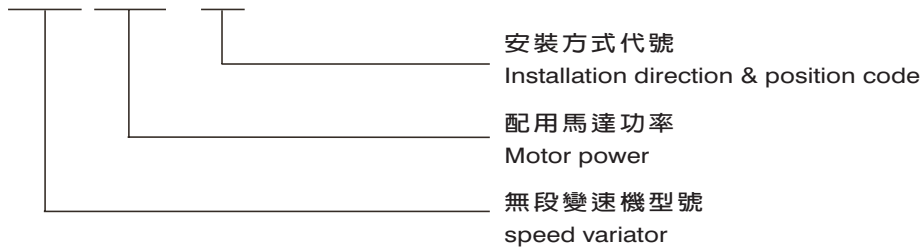

## 特性表 Performance

n1	馬達功率	TK/TKF/TXF	n2 max	n2 min	M2 min	M2 max	滑差率 %	溫升 < °C
1400	0.18KW/4P	002	880	170	1.5	3	3-3.8	46
	0.37KW/4P	005	1000	170	3	6	3-8.8	46
	0.75KW/4P	010	1000	170	6	12	3-8.8	46
	1.5KW/4P	020	950	165	12	24	3-8.8	46
	2.2KW/4P	030	1000	200	18	36	3-8.8	46
	4KW/4P	050	1000	200	32	64	3-8.8	46
	5.5KW/4P	100	1000	200	45	90	3-8.8	50
	7.5KW/4P	100	1000	200	59	118	3-8.8	50

## 馬達安裝尺寸 Motor hicky

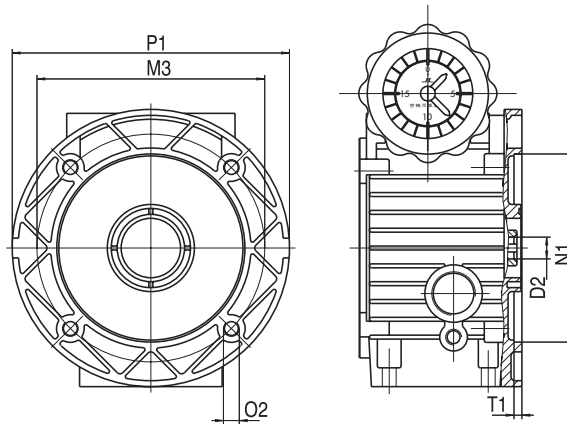

TK/TKF/TXF	PAM IEC	P1	N1(H8)	M3	O2	D2(F7)	T1
<b>002</b>	63B5	140	95	115	M8	11	5
<b>005</b>	71B5	160	110	130	M8	14	5
<b>010</b>	80B5	200	130	165	M10	19	6
<b>020</b>	90B5	200	130	165	M10	24	6
<b>030</b>	100B5	250	180	215	M12	28	6
<b>050</b>	112B5						
<b>100</b>	132B5	300	230	265	M12	38	6

## 安裝方式 Mounting

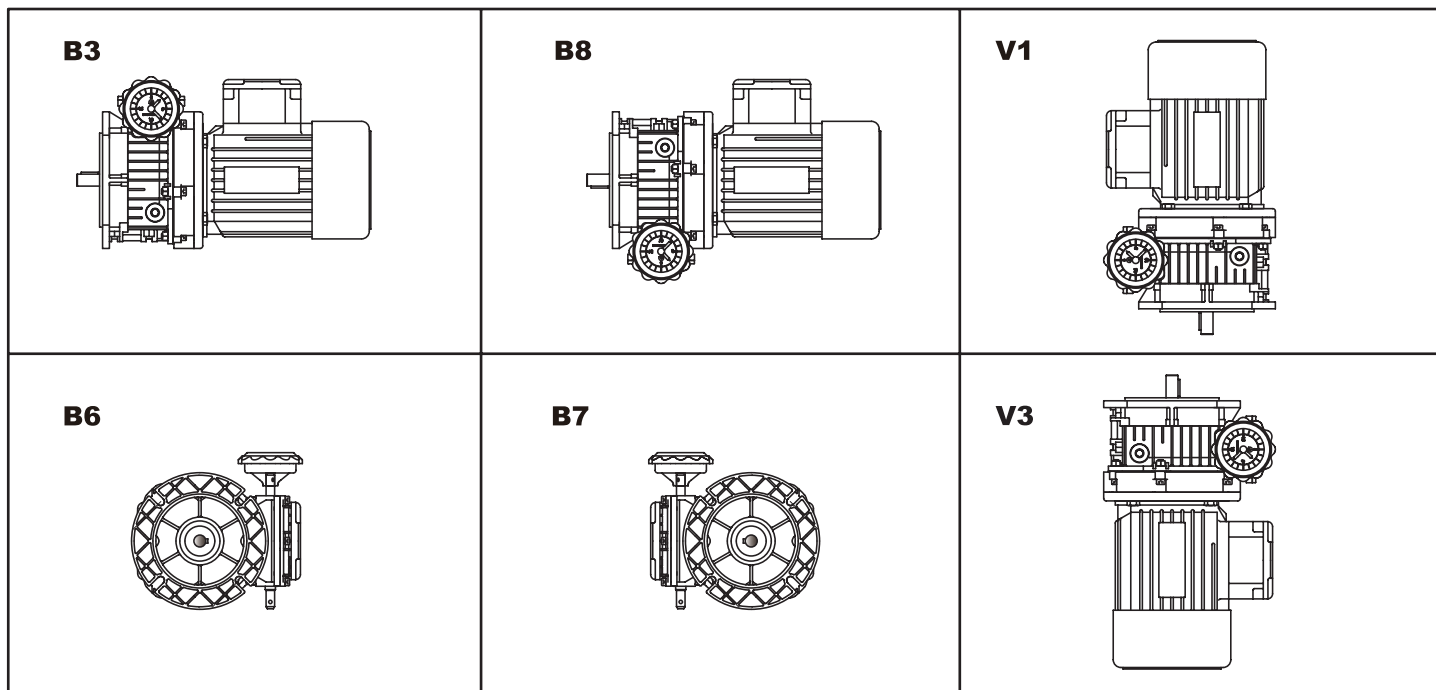

## 油量表 Choice of lubricant

TK/TKF	B3-B6-B7	B8-V1-V3
002	0.12	0.26
005	0.15	0.75
010	0.42	1.7
020	0.4	2.6
030	1.1	5.5
050	1.1	5.5
100	2.07	9

TXF	B3-B6-B7	B8-V1-V3
002	0.1	0.25
005	0.13	0.4
010	0.33	0.75

廠牌	油品型號
IP	TRANSMISSION V.E.
IP	A.T.F. DEXRON FLUID
AGIP	A.T.F. DEXRON
SHELL	A.T.F. DEXRON
ESSO	A.T.F. DEXRON
CHEVRON	A.T.F. DEXRON
FINA	A.T.F. DEXRON
MOBIL	MOBIL A.T.F 220
CASTROL	TQ DEXRON II
BP	AUTRAN DX

手輪位置圖  
Hand-wheel position diagram

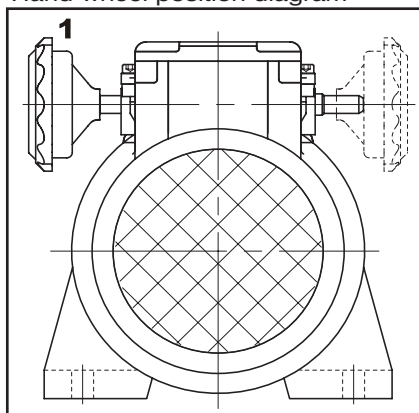

馬達結線盒位置圖  
Motor terminal box position diagram

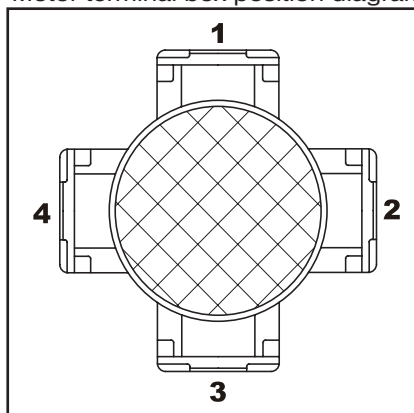

### B3外形尺寸 Dimensions for B3 model

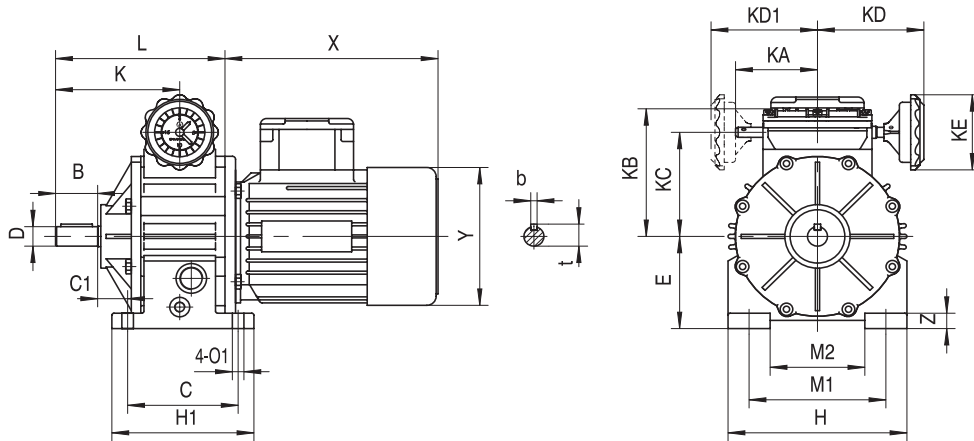

TYPE	B	D(j6)	C	C1	E	H	H1	K	L	M1	M2	O1	KA	KB	KC	KD	KD1	KE	b	t	X	Y	Z
TK002	23	11	105	17.5	80	145	120	87.5	135.5	110	71	9	71	111	78	110	110	85	4	12.5	200	120	10
TK005	30	14	104	20	93	149	125	104	140	120	96	9	71	123	90	110	110	85	5	16	227	141	10
TK010	40	19	125	26	113	190	150	125.5	179	160	135	11	79	140	107	120	120	110	6	21.5	268	160	15
TK020	50	24	115	53.5	123	241	150	165	238	190	143	13	-	144	122	150	-	110	8	27	290	195	18
TK030	60	30	230	25	150	300	270	191	268	245	190	14	-	188	150	160	-	110	8	33	320	215	25
TK050	60	30	230	25	150	300	270	191	268	245	190	14	-	188	150	160	-	110	8	33	340	240	25
TK100	70	35	250	33	200	365	290	201	319	315	245	18	-	-	192	194	-	110	10	38	435	275	30

### B5外形尺寸 Dimensions for B5 model

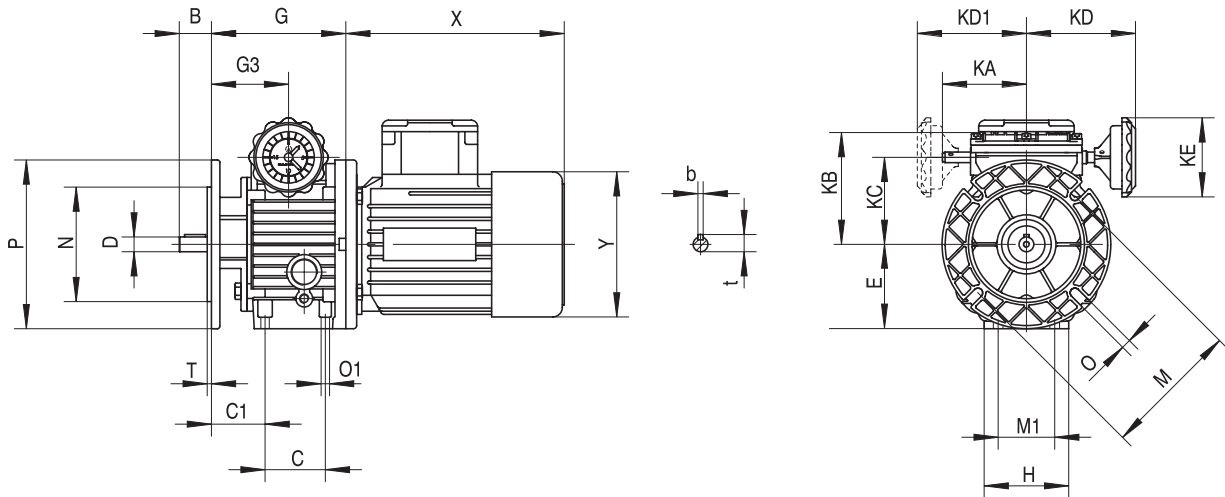

TYPE	B	D(j6)	C	G	G3	E	H	M	M1	N	O	O1	P	T	C1	KA	KB	KC	KD	KD1	KE	b	t	X	Y	Z
TKF/TF002	23	11	50	112.5	64.5	70	72	115	60	95	9	M6	140	3.5	46	71	111	78	110	110	85	4	12.5	200	120	10
TKF/TF005	30	14	40	110	74	80	90	130	77	110	9	M8	160	3.5	53	71	123	90	110	110	85	5	16	227	141	10
TKF/TF010	40	19	58	139	85.5	100	98	165	84	130	11	M8	200	3.5	60	79	140	107	120	120	110	6	21.5	268	160	15
TKF020	50	24	-	188	115	126	241	165	-	130	11	-	200	3.5	-	-	144	122	150	-	110	8	27	290	195	18
TKF030	60	30	-	208	131	150	270	265	-	230	15	-	300	4	-	-	188	150	160	-	110	8	33	320	215	25
TKF050	60	30	-	208	131	150	270	265	-	230	15	-	300	4	-	-	188	150	160	-	110	8	33	340	240	25
TKF100	70	35	-	244	131	200	-	300	-	250	19	-	350	5	-	-	-	192	194	-	110	10	38	435	275	30